

DUCT TESTING & SEALING

© 2002 Saturn Resource Management, Inc.
www.srmi.biz

Published by:
USDOE
Seattle Regional Office

ENERGY
Out West
A Holistic Approach

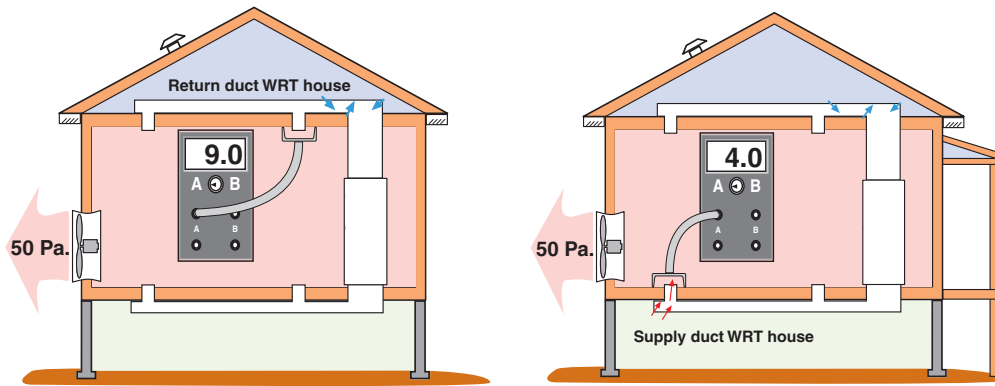

Recommendations: Pressure Pan Testing

Pressure pan testing helps to locate duct air leaks without inspecting or needlessly sealing the whole duct system.

1. Open interior doors to connect all conditioned living spaces together. Close doors to outdoors and to unconditioned areas like crawl spaces.
2. Install a blower door and depressurize the house to -50 pascals.
3. Cover each register with the pressure pan, which is connected to the input port of a digital manometer and reads positive pressure cause by air leaking into the ductwork from outdoors.
4. Registers registering numbers greater than 2 pascals reflect nearby duct leakage or general duct leakage.
5. Using the pressure pan and blower door as your guide, find and seal the largest duct air leaks.
6. Readings less than 1 pascal are considered good.

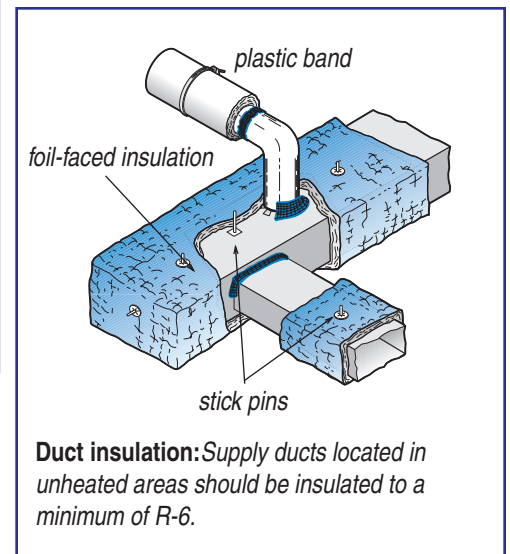

Recommendations: Finding Duct Leaks by Touch and Sight

1. Use a light and inspection mirror to look into the ducts and inspect joints.
2. Use the air handler blower to pressurize supply ducts. Closing the dampers on supply registers temporarily or partially blocking the register with pieces of carpet, magazines, or any object that won't be blown off by the register's airflow will increase the duct pressure and make duct leaks easier to find.
3. Place a trouble light, with a 100-watt bulb, inside the duct through a register. Look for light emanating from the exterior of duct joints and seams.
4. Recognize which duct joints were difficult to fasten and seal during original installation. These joints are likely duct-leakage locations.

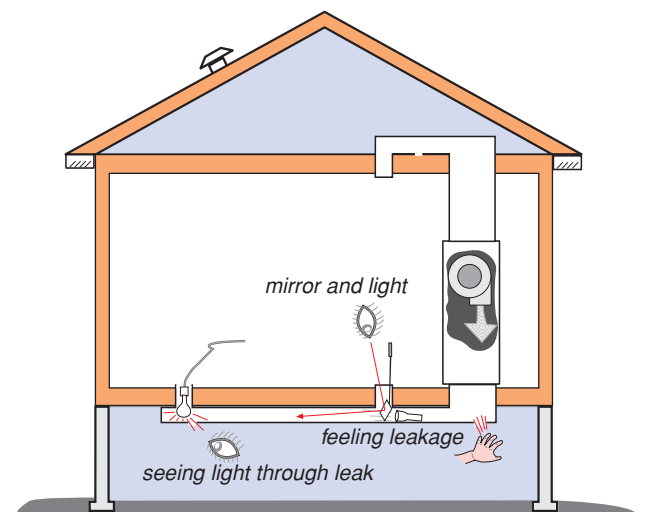

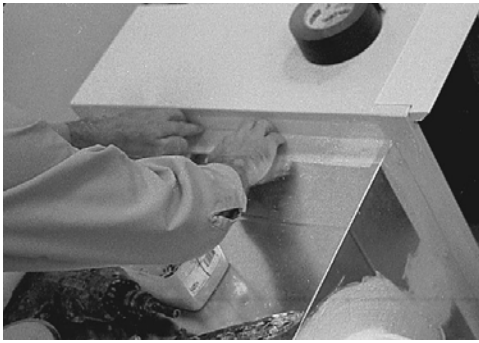

Plenums: Joints in the plenum can be major leakage locations. The best plenums are metal, sealed with mastic and fabric webbing. Use silicone caulking between the air handler and plenum if you think the air handler could be replaced.

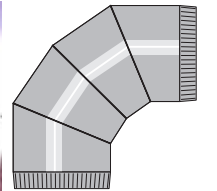

Tabbed sleeve and sectioned elbow

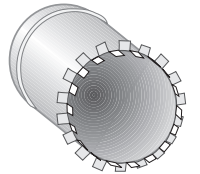

Recommendations: Duct Leak Locations

The following is a list of duct-leak locations in order of their relative importance. Leaks nearer to the air handler see higher pressure and so rank higher than leaks further away.

Air handler. Leaks in the air handler are the top air-sealing priority.

Plenum joints at air handler. These joints may have been difficult to fasten and seal because of tight access. Go the extra mile to seal them airtight with mastic and fabric mesh tape.

Joints at branch takeoffs. These important joints should be sealed with a thick layer of mastic. Fabric mesh tape is a plus for new installations or when access is easy.

Joints in sectioned elbows. Known as gores, these are usually leaky.

Large holes. Seal with metal patch and mastic.

Tabbed sleeves. Attach the sleeve to the main duct with 4-to-6 screws and lay on the mastic.

Joints in main-duct sections. Make sure these sections have a couple screws on each side fastening them together. Run mastic and mesh tape around the joint.

Ductboard with loose tape. Clamp the flexduct's inner liner with the strap tightener. Run a screw or two next to the strap when the flexduct is pulling slightly on the metal collar to keep it from separating. Clamp the insulation and outer liner with another strap.

Ductboard with loose tape. Dust the surfaces off as best you can first. Stick the tape back on with mastic and mastic over the tape. When the customer can afford it, trash the ductboard and give them a new extended-plenum metal system.



Sealing a tabbed sleeve inside a rooftop unit's plenum

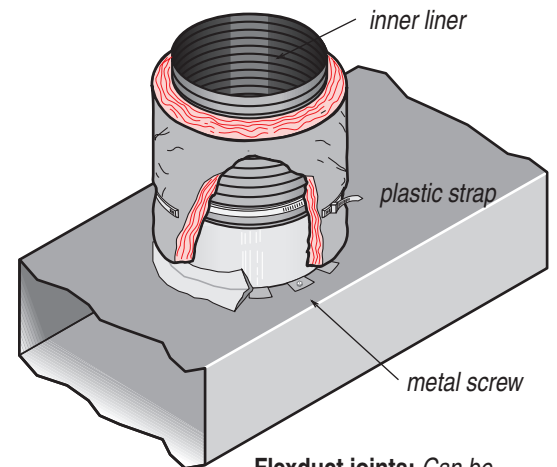

Flexduct joints: Can be very airtight if prepared or repaired correctly.

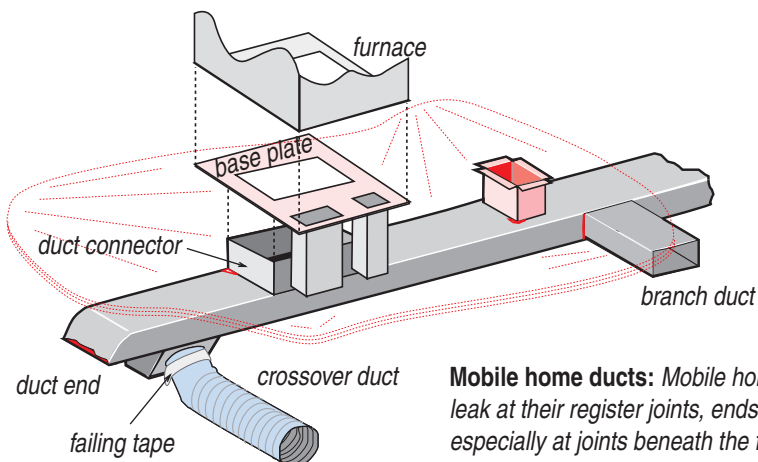

Mobile home ducts: Mobile home ducts leak at their register joints, ends, and especially at joints beneath the furnace.

